

CAL™ : Column Array Loudspeaker



The CAL steerable column array loudspeaker combines over three decades of technological innovation and advanced research into the laws of physics and digital signal processing to achieve unprecedented accuracy in sound reproduction. Designed primarily for vocal reproduction in fixed installations, the self-powered CAL offers variable vertical beam coverage (as narrow as 5 degrees and as wide as 30 degrees) that can be digitally steered up or down by 30 degrees. CAL's beam steering takes the practice of directing sound to the next level, and with a smart, lean profile, CAL sets the standard for high-quality sound installations.

CAL is available in three models, each providing a different output level — up to a maximum peak SPL of 106 dB at 90 meters with CAL 96 — over an operating frequency range of 100 Hz to 16 kHz. Providing a horizontal coverage of 120 degrees, as well as the flexibility of vertical beam steering, a single unobtrusive CAL delivers clear vocal reproduction over a large area while minimizing undesirable reflections.

Discrete onboard Class D amplifier channels, processed by sophisticated algorithms, power each driver and tweeter. The amplitude and phase responses of each driver are engineered to produce interactions that yield the desired vertical coverage. Controlling each element individually yields greater flexibility and precision than other beam steering systems that control modules comprised of multiple drivers.

The accuracy of CAL's vertical steering allows system designers to pinpoint coverage, even when mounting options in a venue do not allow for physically aiming a loudspeaker toward a coverage area. CAL 96 and CAL 64 include split beams that can be configured to fit the application, for example, to avoid hitting a reflective balcony surface. To meet the high intelligibility requirement for vocal reproduction, CAL has been engineered to maintain accurate beam steering up to 10 kHz, well beyond the benchmark of 4 kHz used in traditional single-driver loudspeakers.



CAL 96
Amplifier 96 channels
Transducers (24) 4" drivers
 (72) 20 mm tweeters

CAL 64
Amplifier 64 channels
Transducers (16) 4" drivers
 (48) 20 mm Tweeters

CAL 32
Amplifier 32 channels
Transducers (8) 4" drivers,
 (24) 20 mm tweeters

CAL loudspeakers include two AVB-enabled Ethernet ports for receiving AVB audio streams as source signals. The ports also provide computer control of CAL via Meyer Sound's Compass control software, allowing beam control and RMS™ real-time monitoring of each loudspeaker on the network.

CAL comes standard with adjustable mounting brackets for installation on walls or columns. The low-profile aluminum enclosure is available in white, black, and custom colors, allowing it to blend easily into any background. Weather protection permits outdoor installations in most environments.

FEATURES & BENEFITS

- Variable vertical coverage from 5° to 30°
- 60° of vertical beam steering, ±30°
- Proprietary drivers optimized for high output and low distortion
- Discrete amplifier channels and signal processing for each driver and tweeter
- AVB-enabled Ethernet ports for audio streaming and computer control

- Compass control software provides control of CAL's beam configurations, as well as RMS real-time monitoring of loudspeaker parameters
- Low profile enclosure and custom colors blend into any environment
- Weather protection and rain hood included for outdoor installations

APPLICATIONS

- Airports
- Convention centers
- Stadiums
- Places of worship
- Shopping malls and retail spaces
- Reverberant spaces requiring low-profile sound reinforcement for voice

CAL ARCHITECT SPECIFICATIONS (ALL MODELS)

The loudspeaker shall be a self-contained, steerable, column array system with discrete array modules, each comprised of a 4-inch cone driver, six 20-mm tweeters, and multiple Class D amplifier channels. Onboard processing shall include 5-band parametric EQ, delay, and gain.

Horizontal coverage shall be 120 degrees. Vertical coverage shall be variable from 5 degrees to 30 degrees in 5-degree increments. Vertical beam steering shall be from ±30 degrees in 1-degree increments.

Performance specifications for a typical production unit shall be as follows, measured at 1/3-octave resolution: operating frequency range, 100 Hz to 16 kHz; frequency response, 105 Hz to 15 kHz ±4 dB; phase response, 230 Hz to 16.9 Hz ±45 degrees.

Three Phoenix 6-pin male connectors shall be included for balanced analog audio input and loop output. Audio input shall be electronically balanced with a 10 kOhm impedance and accept a nominal 0 dBV (1.0 V rms, 1.4 V peak) signal. An additional Phoenix 6-pin male connector shall be included for AES/EBU digital input. Two AVB-enabled Network ports shall be included for input from digital audio streams.

Power requirements shall be nominal 100, 110, or 230 V AC line current at 50 or 60 Hz. UL and CE operating voltage range shall be 100 to 240 V AC. The AC power connector shall be PowerCon.

The loudspeaker shall include two control ports: one Phoenix 6-pin male connector for selecting onboard presets and reporting loudspeaker faults; and one Phoenix 5-pin male

connector for triggering emergency mute and input override.

The AVB-enabled Network ports shall also provide computer control of the loudspeaker via Meyer Sound's Compass control software. The Compass control software shall also include RMS remote monitoring of loudspeaker performance parameters.

Loudspeaker components shall be mounted in an extruded aluminum enclosure available in white, black, and custom colors. Weather protection and a user panel cover shall be included for outdoor installations. Brackets shall be included for fixed mounting on walls and columns.

The loudspeakers shall be the Meyer Sound CAL 96, CAL 64, and CAL 32.

CAL 96

The loudspeaker shall include 96 amplifier channels driving (24) 4-inch cone drivers and (72) 20 mm tweeters. Maximum peak SPL shall be 106 dB peak at 90 m (295 ft). Current draw during burst (< 1 sec) shall be 14.7 A rms at 115 V, 7.3 A rms at 230 V AC, and 18.5 A peak at 100 V AC.

The loudspeaker shall provide a top split beam coverage with the top beam emanating from the top 32 drivers and the bottom beam emanating from the bottom 64 drivers. The loudspeaker shall also provide a bottom split beam coverage with the top beam emanating from the top 64 drivers and the bottom beam emanating from the bottom 32 drivers. Split beams shall be available with variable vertical coverage and vertical steering.

Dimensions with mounting hardware shall be 7.75" wide x 121.12" high x 9.93" deep (197 mm x 3076 mm x 252 mm). Weight with mounting hardware shall be 173 lbs (78.5 kg).

The loudspeaker shall be the Meyer Sound CAL 96.

CAL 64

The loudspeaker shall include 64 amplifier channels driving (16) 4-inch cone drivers and (48) 20 mm tweeters. Maximum peak SPL shall be 106 dB peak at 60 m (196 ft). Current draw during burst (< 1 sec) shall be 10.8 A rms at 115 V, 5.4 A rms at 230 V AC, and 13.6 A peak at 100 V AC.

The loudspeaker shall provide a center split beam coverage with the top beam emanating from the top 32 drivers and the bottom beam emanating from the bottom 32 drivers. Split beams shall be available with variable vertical coverage and vertical steering.

Dimensions with mounting hardware shall be 7.75" wide x 87.72" high x 9.93" deep (197 mm x 2228 mm x 252 mm). Weight with mounting hardware shall be 124 lbs (56.2 kg).

The loudspeaker shall be the Meyer Sound CAL 64.

CAL 32

The loudspeaker shall include 32 amplifier channels driving (8) 4-inch cone drivers and (24) 20 mm tweeters. Maximum peak SPL shall be 106 dB peak at 30 m (98 ft). Current draw during burst (< 1 sec) shall be 5.9 A rms at 115 V, 2.9 A rms at 230 V AC, and 7.4 A peak at 100 V AC.

The loudspeaker shall provide only single-beam coverage.

Dimensions with mounting hardware shall be 7.75" wide x 54.32" high x 9.93" deep (197 mm x 1380 mm x 252 mm). Weight with mounting hardware shall be 80 lbs (36.3 kg).

The loudspeaker shall be the Meyer Sound CAL 32.



CAL User Panel

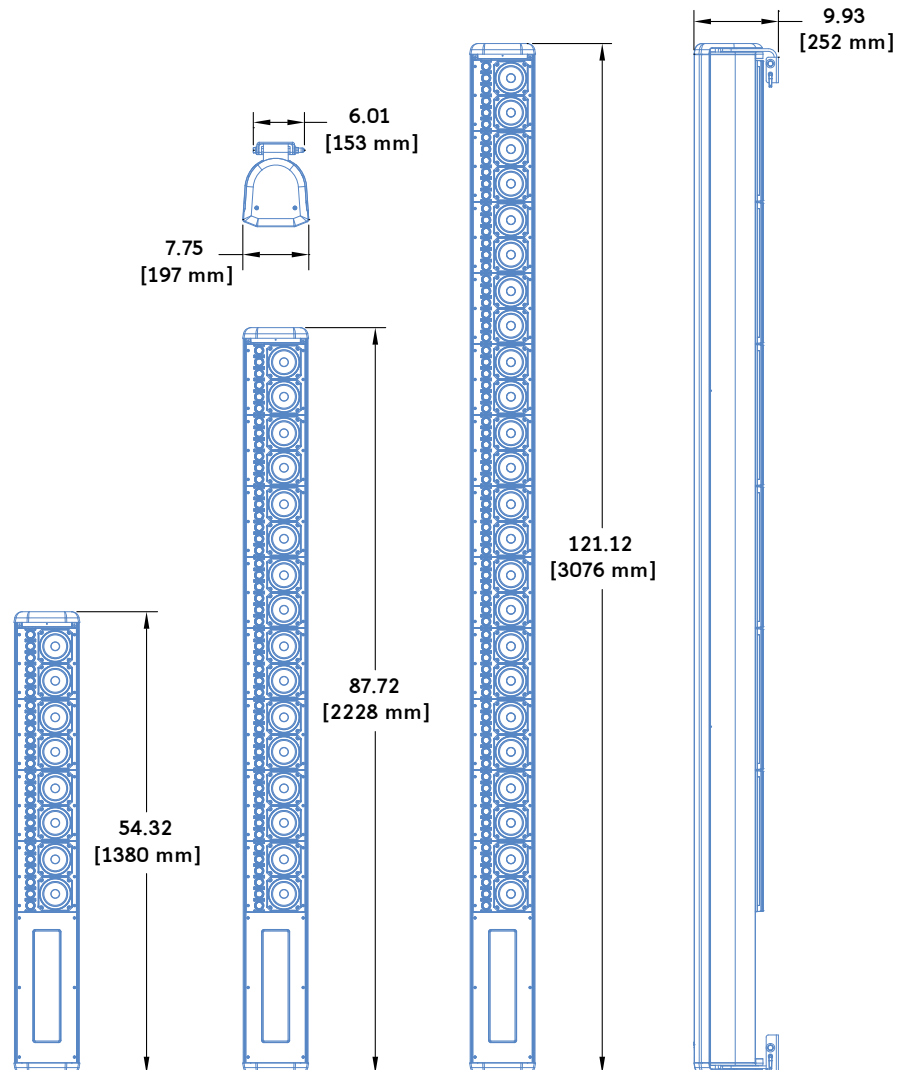

VARIABLE VERTICAL COVERAGE AND BEAM STEERING

CAL loudspeakers provide vertical beams with variable coverage from 5 to 30 degrees in 5-degree increments. The vertical beams can also be steered ± 30 degrees in 1-degree increments.

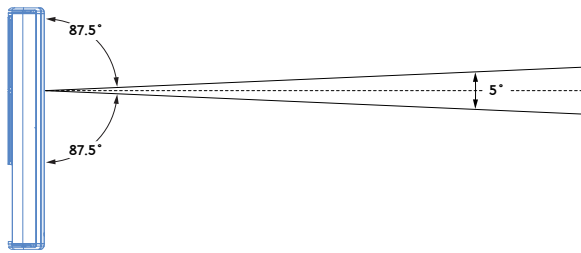

CAL 32, 5-Degree Beam

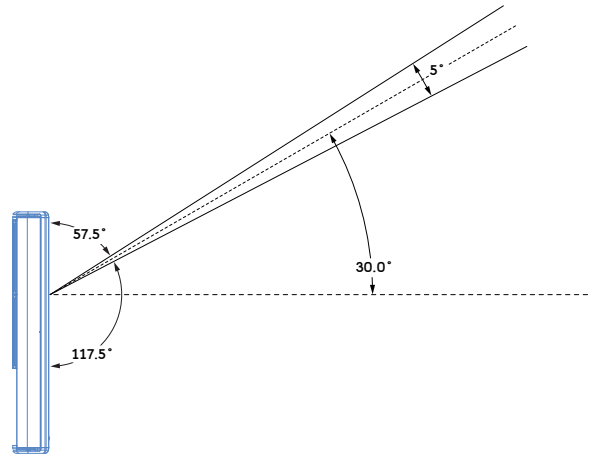

CAL 32, Beam Steered +30 Degrees

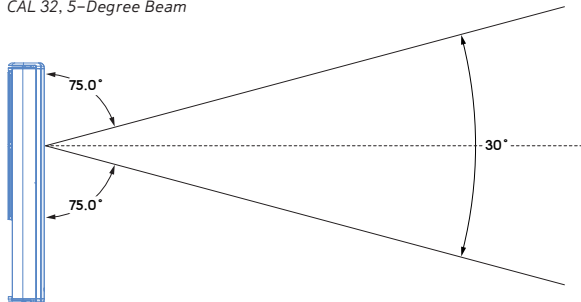

CAL 32, 30-Degree Beam

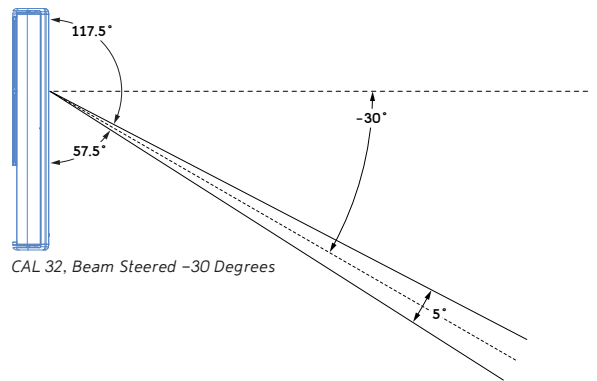

CAL 32, Beam Steered -30 Degrees

VERTICAL BEAM SPLITS

CAL 96 and CAL 64 provide split beam coverages to aim sound toward two destinations or to avoid reflective surfaces such as a balcony. The split beams can also be configured with the desired vertical coverage and steering.

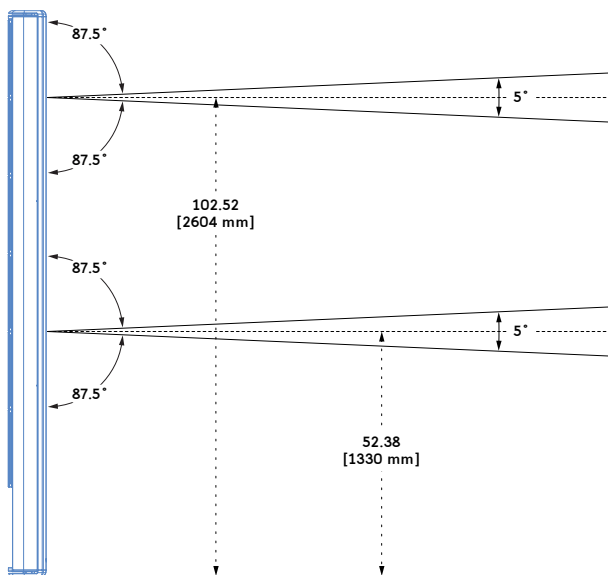

CAL 96, Top Split Beam Coverage

COMPASS CONTROL SOFTWARE

The Compass control software provides comprehensive control of CAL through a graphical user interface. The software enables easy access to all CAL features and even provides control of multiple units. Compass runs on a Mac or Windows®-based computer.

With Compass, you can set the active input and override input; configure vertical beam coverage, beam steering, and beam splits; assign processing to beams, including gain, delay, and parametric EQ; edit, store, recall, and organize CAL presets; test logic I/O, including input mute, input override, fault, contact, and preset selection, and monitor loudspeaker system status and performance data from the RMS tab.

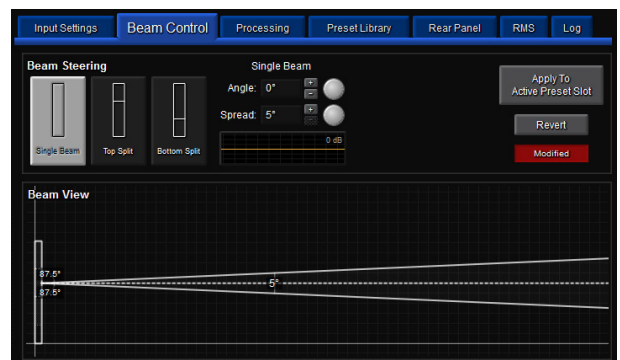

The Beam Control tab displays CAL's vertical beam coverage (spread) and vertical steering, both of which can be altered by entering angle values or by dragging in the beam view area. Split beams can also be configured on the Beam Control tab (CAL 64 and CAL 96 only).

CAL SPECIFICATIONS

ACOUSTICAL			
Operating Frequency Range ¹	100 Hz – 16 kHz		
Frequency Response ²	105 Hz – 15 kHz ±4 dB		
Phase Response	230 Hz – 16.9 kHz ±45°		
Maximum Peak SPL ³	CAL 96 106 dB peak at 90 m (295 ft)		
	CAL 64 106 dB peak at 60 m (196 ft)		
	CAL 32 106 dB peak at 30 m (98 ft)		
COVERAGE			
Horizontal	120°		
Vertical	Variable, 5° to 30° in 5° increments		
Vertical Steering	±30° in 1° increments		
Vertical Beam Splits	CAL 96 Top split, bottom split		
	CAL 64 Center split		
	CAL 32 None		
CROSSOVER			
	2 kHz ⁴		
TRANSDUCERS			
	CAL 96 (24) 4" cone drivers, (72) 20 mm tweeters		
	CAL 64 (16) 4" cone drivers, (48) 20 mm tweeters		
	CAL 32 (8) 4" cone drivers, (24) 20 mm tweeters		
AUDIO/CONTROL			
Analog Audio	(3) Phoenix 6-pin male connectors for balanced audio input and loop output		
Digital Audio ⁵ Network / AVB ⁶	(1) Phoenix 6-pin male connector for AES/EBU input (2) AVB-enabled Ethernet ports for audio streaming, and beam control and RMS monitoring via Compass control software		
Processing ⁷	Mute, gain, 5-band parametric EQ, and delay, stored in four onboard presets		
Logic I/O	Phoenix 6-pin male connector, recalls onboard presets, reports relay closures (and openings) for fault reports; Phoenix 5-pin male connector, triggers emergency mute and input override		
Display	OLED button displays CAL's network addresses during startup or when the button is pushed		
AMPLIFIER			
Type	Multichannel Class D, one channel per driver		
Cooling	Convection		
AC POWER			
Connector	PowerCon		
Voltage Selection	Automatic, continuous from 90–235 V AC		
Safety Agency Rated Operating Range	100–240 V AC, 50/60 Hz		
Current Draw: Idle Current	115 V AC	230 V AC	100 V AC
	CAL 96 1.98 A rms	1.63 A rms	2.32 A rms
Max. Long-Term Continuous Current (>10 sec)	CAL 64 1.24 A rms	0.99 A rms	1.42 A rms
	CAL 32 0.58 A rms	0.45 A rms	0.65 A rms
	CAL 96 8.3 A rms	4.2 A rms	9.4 A rms
Burst Current (<1 sec)	CAL 64 6.1 A rms	3.1 A rms	6.9 A rms
	CAL 32 3.3 A rms	1.7 A rms	3.7 A rms
	CAL 96 14.7 A rms	7.3 A rms	18.5 A rms
Ultimate Short-Term Peak Current	CAL 64 10.8 A rms	5.4 A rms	13.6 A rms
	CAL 32 5.9 A rms	2.9 A rms	7.4 A rms
	CAL 96 33 A peak	18 A peak	40 A peak
	CAL 64 24 A peak	13 A peak	29 A peak
	CAL 32 13 A peak	7 A peak	16 A peak
PHYSICAL			
Enclosure	Extruded aluminum		
Finish	White, black, and customer colors		
Weather Protection	Suitable for outdoor installations, rain hood included		
Mounting	Adjustable brackets included for mounting on columns or walls		
Dimensions (with Mounting Hardware)	CAL 96 121.12" h x 7.75" w x 9.93" d (3076 mm x 197 mm x 252 mm)		
	CAL 64 87.72" h x 7.75" w x 9.93" d (2228 mm x 197 mm x 252 mm)		
	CAL 32 54.32" h x 7.75" w x 9.93" d (1380 mm x 197 mm x 252 mm)		
Weight (with Mounting Hardware) ⁸	CAL 96 173 lbs (78.5 kg)		
	CAL 64 124 lbs (56.2 kg)		
	CAL 32 80 lbs (36.3 kg)		

NOTES:

1. Recommended maximum operating frequency range. Response depends on loading conditions and room acoustics.
2. Measured free field with 1/3 octave frequency resolution at 4 meters.
3. Measured with single beam, 5-degree vertical coverage, and no steering.
4. At this frequency, the transducers produce equal sound pressure levels.
5. The connector's bottom three pins are not used.
6. Second Ethernet port provided for redundant control.
7. Processing and beam settings can be edited in Compass control software and saved in four onboard presets.
8. Weights include top and bottom loudspeaker brackets, top and bottom endcaps.



CAL — 04.210.086.01 A

Copyright © 2012
Meyer Sound Laboratories Inc.

MEYER SOUND LABORATORIES INC.
2832 San Pablo Avenue
Berkeley, CA 94702

T: +1 510 486.1166
F: +1 510 486.8356

techsupport@meyersound.com
www.meyersound.com